

Umbauset

Conversion kit | Set de transformation | Set di conversione

Montageanleitung

Assembly instructions | Instructions de montage | Manuale di assemblaggio

Ehrenkind

Lieferumfang prüfen

1. Nimm die Einzelteile aus der Verpackung.
2. Prüfe, ob die Lieferung vollständig ist.
3. Prüfe, ob das Produkt, die Einzelteile oder das Zubehör Schäden aufweisen. Ist dies der Fall, benutze das Produkt nicht. Wende dich direkt an uns über die angegebene Adresse.

Bitte beachte die Hinweise im Kapitel Montagehinweise!

- 1 2 x Seitenteil Hinten
- 1a 2 x Seitenteil Vorne
- 2 2 x Rausfallschutz Hinten Oben
- 2a 1 x Seitenteil Hinten / Verbindungsstück
- 3 2 x Rausfallschutz Vorne Oben
- 4 2 x Kopf / Fußseite vormontiert Unten
- 5 2 x Kopf / Fußseite vormontiert Oben
- 6 1 x Längsholm Leiter Links Hoch
- 6a 1 x Längsholm Leiter Rechts Hoch
- 7 3 x Sprosse Leiter
- 8 4 x Kopf / Fußteil Verbindungsstück
- 9 2 x Rollrost mit Band
- Z1 2 x Abstandshalter Hoch Vorne
- Z2 1 x Abstandshalter Hoch Hinten Links
- Z3 1 x Abstandshalter Hoch Hinten Rechts
- A 14 x Schraube (M6x100)
- B 3 x Schraube (M6x75)
- C 2 x Schraube (M6x60)
- D 4 x Quermutter (M6 10x14)
- E 3 x Mutter (M6 9x15)
- F 12 x Holzschraube (7x50)
- G 16 x Holzdübel (12x60)
- H 36 x Holzdübel (8x35)
- J 18 x Holzschraube (4x35)
- K 1 x Inbusschlüssel



Checking scope of delivery

1. Take the individual components out of the packaging.
2. Check whether the delivery is complete.
3. Check whether the product, the individual components or accessories are damaged. If this is the case, do not use the product. Contact us directly at the address provided.

Please note the information in the chapter on assembly instructions!

- 1 2 x Side part rear
- 1a 2 x Side part front
- 2 2 x Fall guard rear top
- 2a 1 x Side part rear / connector
- 3 2 x Fall guard front top
- 4 2 x Head / foot side preassembled bottom
- 5 2 x Head / foot side preassembled top
- 6 1 x Longitudinal ladder left high
- 6a 1 x Longitudinal ladder right high
- 7 3 x Rung ladder
- 8 4 x Head / foot Connector
- 9 2 x Rolling grid with belt
- Z1 1 x Ladder part B
- Z2 4 x Ladder rungs
- Z3 2 x Wooden dowel (8x30)
- A 14 x Bolt (M6x100)
- B 3 x Bolt (M6x75)
- C 2 x Bolt (M6x60)
- D 4 x Cross nut (M6 10x14)
- E 3 x Nut (M6 9x15)
- F 12 x Wood screw (7x50)
- G 16 x Wood dowel (12x60)
- H 36 x Wood dowel (8x35)
- J 18 x Wood screw (4x35)
- K 1 x Allen key

Vérification du contenu de la livraison

1. Sortez les différentes pièces de l'emballage.
2. Vérifiez si la livraison est complète.
3. Vérifiez si le produit, les pièces détachées ou les accessoires présentent des dommages. Si tel est le cas, n'utilisez pas le produit. Contactez-nous directement à l'adresse indiquée.

Veuillez tenir compte des informations figurant dans le chapitre sur les instructions de montage!

- 1 2 x Panneau latéral arrière
- 1a 2 x Panneau latéral avant
- 2 2 x Protection contre les chutes arrière en haut
- 2a 1 x Partie latérale arrière / pièce de jonction
- 3 2 x Protection contre les chutes à l'avant en haut
- 4 2 x Tête/pied prémontés en bas
- 5 2 x Tête/pieds prémontés en haut
- 6 1 x Longeron échelle gauche élevé
- 6a 1 x Longeron échelle droite élevé
- 7 3 x Echelon Échelle
- 8 4 x Tête/pied de lit Pièce de jonction
- 9 2 x Grille à enroulement avec bande
- Z1 1 x Échelle part B
- Z2 4 x Échelle barres
- Z3 2 x Cheville en bois (8x30)
- A 14 x Boulon (M6x100)
- B 3 x Boulon (M6x75)
- C 2 x Boulon (M6x60)
- D 4 x Écrou croisé (M6 10x14)
- E 3 x Écrou (M6 9x15)
- F 12 x Vis à bois (7x50)
- G 16 x Chevilles en bois (12x60)
- H 36 x Chevilles en bois (8x35)
- J 18 x Vis à bois (4x35)
- K 1 x Clé Allen



Controllo della fornitura

1. Estrarre le singole parti dall'imballaggio.
2. Controllare che la fornitura sia completa.
3. Controllare se il prodotto, le singole parti o gli accessori sono danneggiati. In tale eventualità, non utilizzare il prodotto. Contattarci direttamente all'indirizzo indicato.

Si prega di osservare le indicazioni nel capitolo "Istruzioni per il montaggio"!

- ❶ 2 x Pannello laterale posteriore
- ❶a 2 x Pannello laterale anteriore
- ❷ 2 x Protezione anticaduta posteriore superiore
- ❷a 1 x Pannello laterale posteriore / pezzo di collegamento
- ❸ 2 x Protezione antiurto nella parte superiore anteriore
- ❹ 2 x Lato testa / lato piedi preassemblati fondo
- ❺ 2 x Lato testa / lato piedi preassemblati top
- ❻ 1 x Scala longitudinale, sinistra, alto
- ❻a 1 x Scala longitudinale, destra, alto
- ❼ 3 x Scala a pioli
- ❽ 4 x Sezione testa/piedi Pezzo di collegamento
- ❾ 2 x Griglia avvolgibile con cinghia
- ❺1 2 x Distanziale alto anteriore
- ❺2 1 x Distanziale alto posteriore sinistro
- ❺3 1 x Distanziale alto posteriore destro
- ❶A 14 x Viti (M6x100)
- ❶B 3 x Viti (M6x75)
- ❶C 2 x Viti (M6x60)
- ❶D 4 x Dadi a croce (M6 10x14)
- ❶E 3 x Dado (M6 9x15)
- ❶F 12 x Viti per legno (7x50)
- ❶G 16 x Tasselli di legno (12x60)
- ❶H 36 x Tasselli di legno (8x35)
- ❶J 18 x Viti per legno (4x35)
- ❶K 1 x Chiave a brugola

Etagenbett montieren
Assembling the bunk bed

Assembler le lit superposé
Montaggio del letto a castello

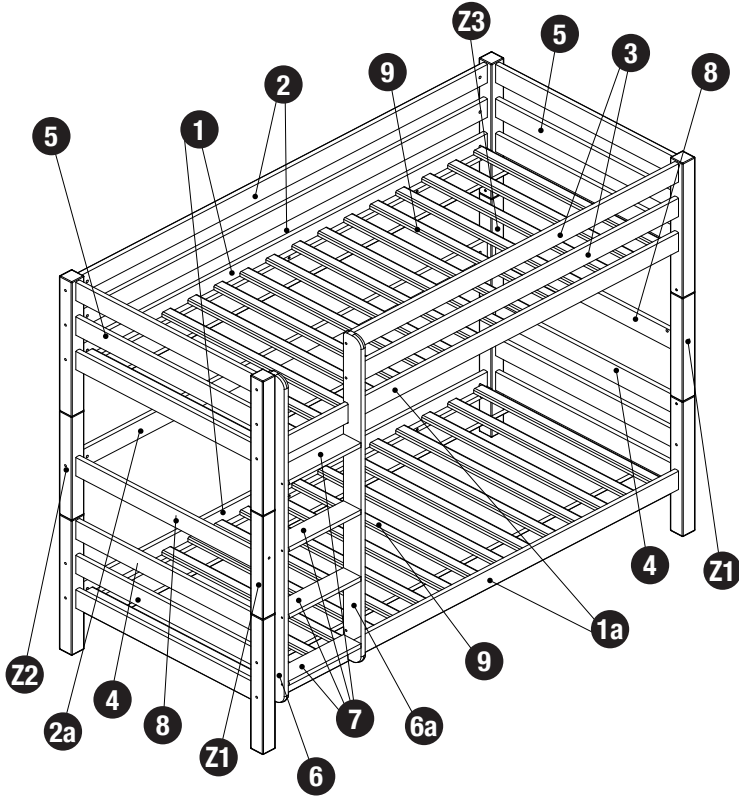

A

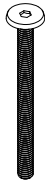

B

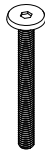

C



D



E



F

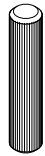

G

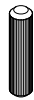

H

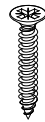

J

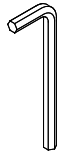

K



01

- 1 x 2a
- 2 x 8
- 12 x H

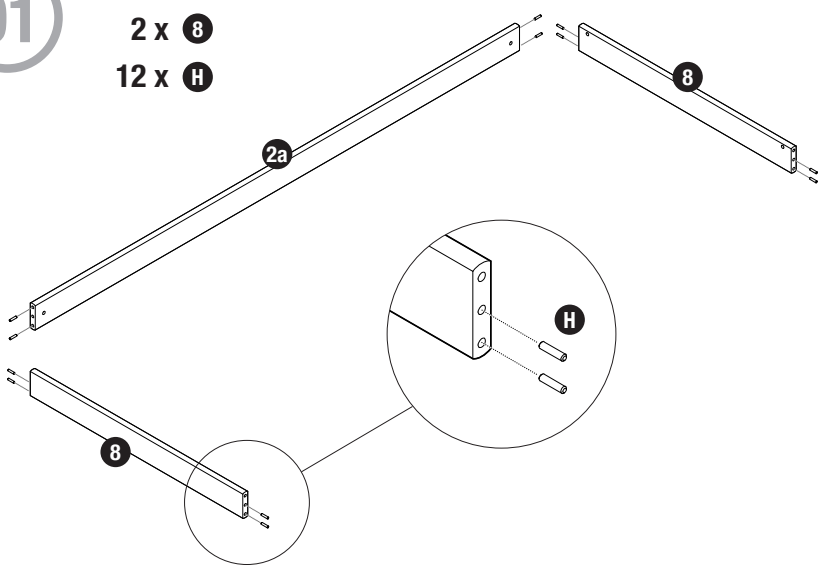

02

- 2 x Z1
- 1 x Z2
- 1 x Z3
- 6 x A
- 6 x D
- 16 x G

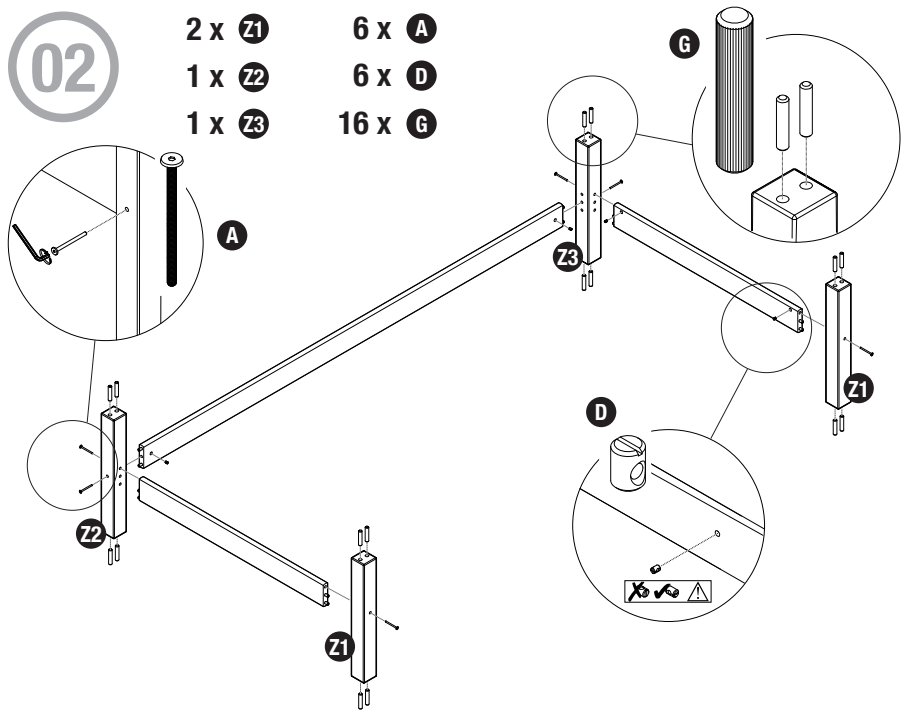

03

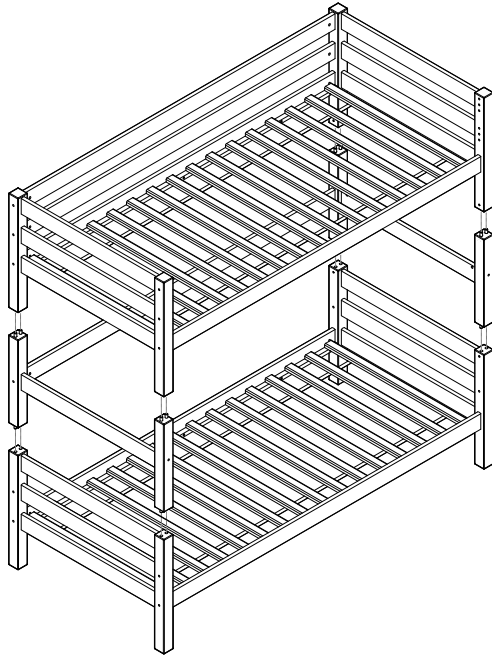

04

8 x J

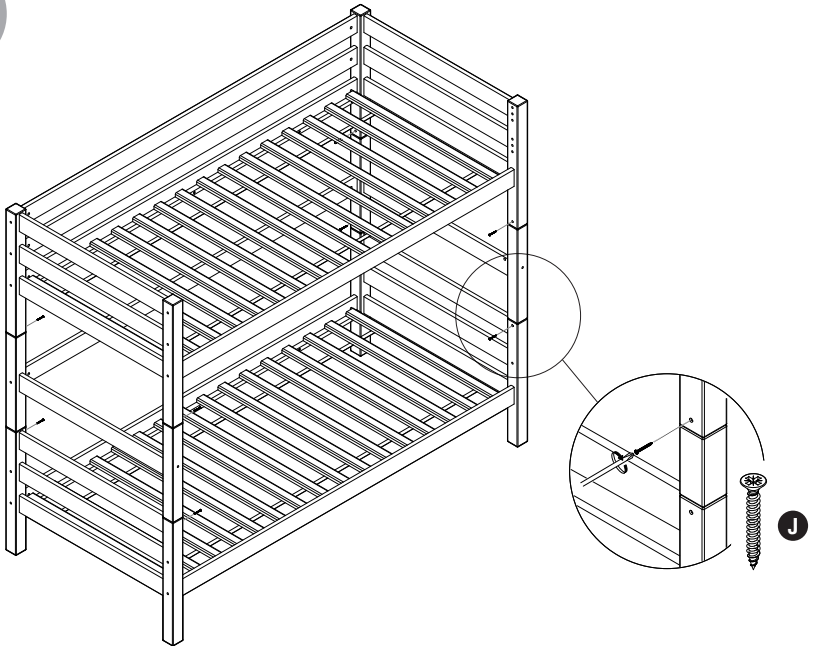

05

1 x 6

4 x 7

1 x 6a

16 x F

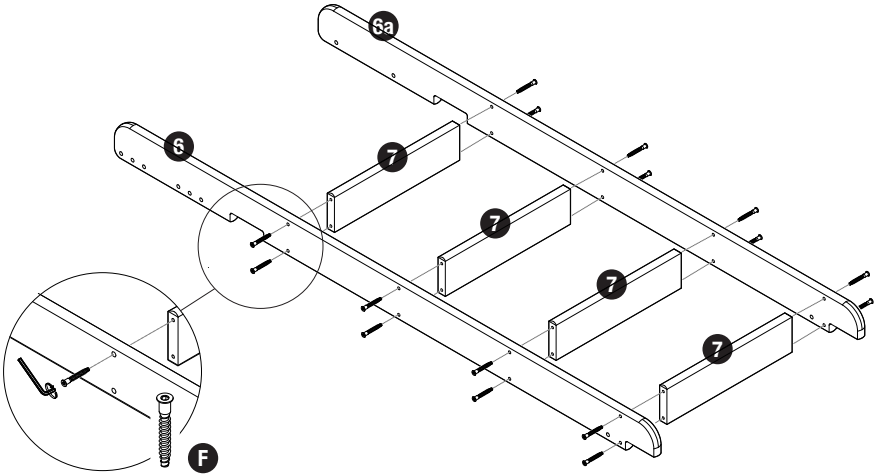

06

18 x H

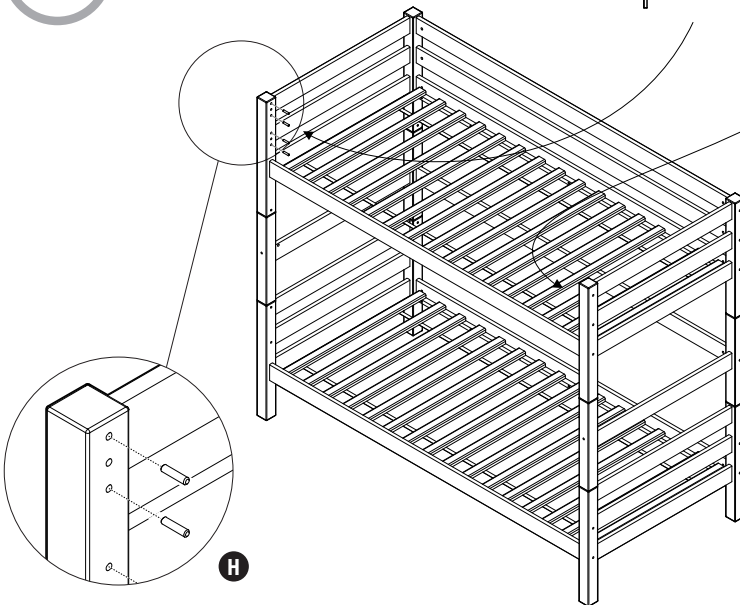
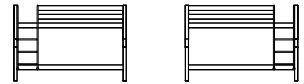

07

2 x 3

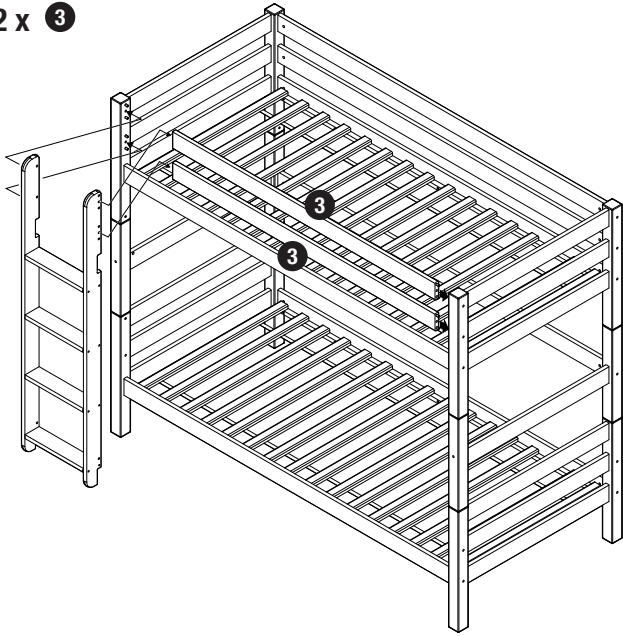

08

2 x A

2 x J

4 x D

2 x C

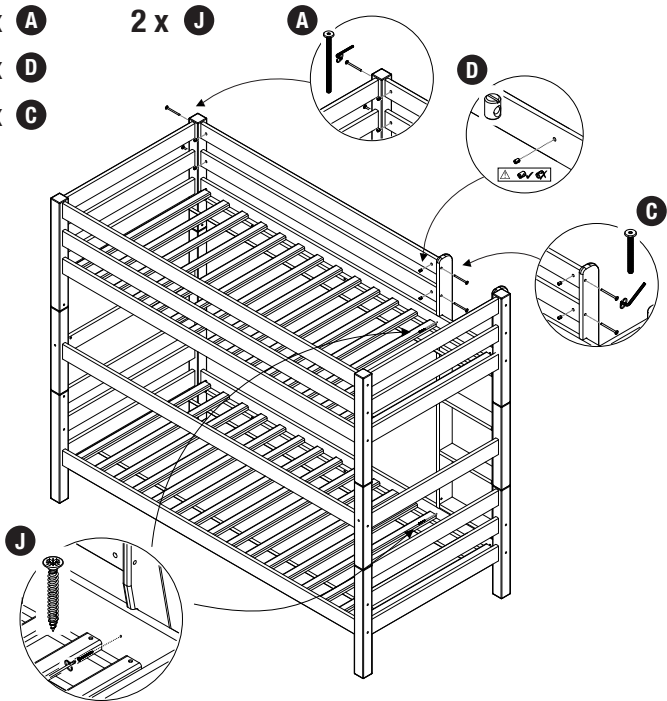

09

3 x B

3 x E

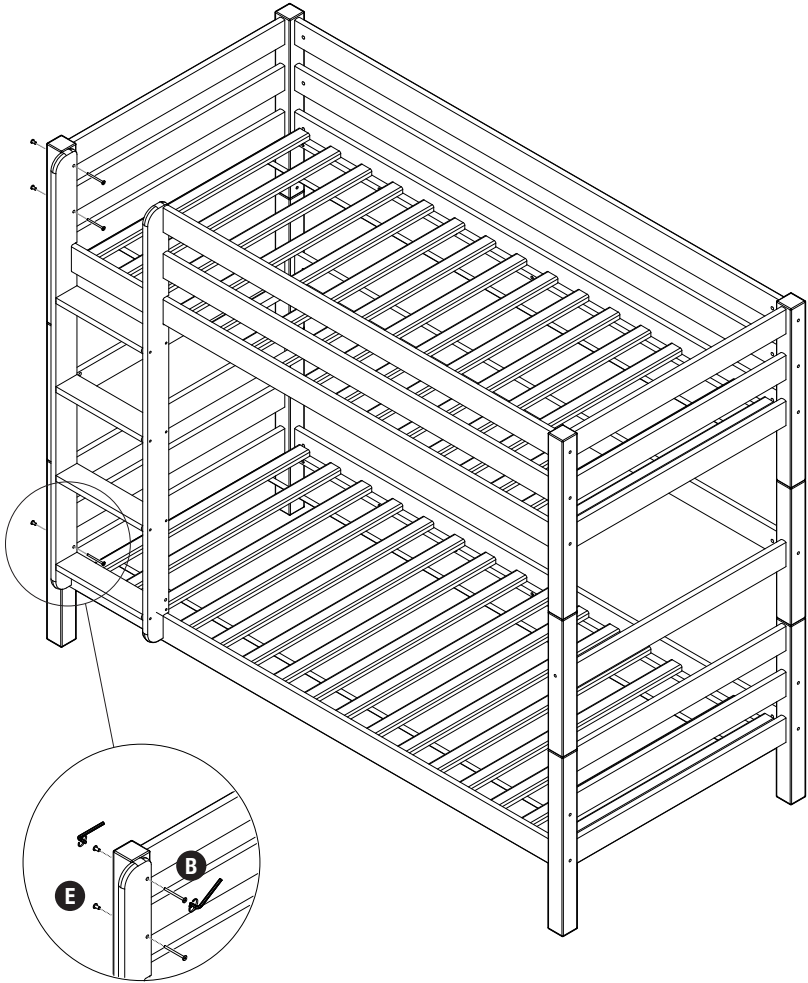

Ehrenkind



Du brauchst Unterstützung?

Besuche unser Serviceportal, scanne einfach den Code mit deinem Smartphone.

Need support?

Visit our service portal, simply scan the code with your smartphone.



Ehrenkind

formbench GmbH
Ginsterweg 3
74523 Schwäbisch Hall