

# Kleiderschrank Linia Kiefer | 100 cm

Wardrobe Linia pine 100 cm | Armoire Linia pin 100 cm |

Armadio Linia pino 100 cm

## **Montageanleitung**

assembly instructions | instructions de montage |  
istruzioni di montaggio

*Ehrenkind*



## Lieferumfang prüfen

1. Nimm die Einzelteile aus der Verpackung.
2. Prüfe, ob die Lieferung vollständig ist.
3. Prüfe, ob das Produkt, die Einzelteile oder das Zubehör Schäden aufweisen. Ist dies der Fall, benutze das Produkt nicht. Wende dich direkt an uns über das Serviceportal.

Bitte beachte die Hinweise in der Montageanleitung!



### Kleiderschrank-Korpus:

- ① 1 × Sockelleiste
- ② 2 × Ober-/Unterboden
- ③ 4 × Rückwand-Verstärkung
- ④ 1 × Seitenteil links
- ⑤ 1 × Seitenteil rechts
- ⑥ 4 × Rückwand
- ⑪ 1 × Kleiderstange
- ⑫ 2 × Einlegeboden
- Ⓐ 18 × Holzdübel Ø8 × 35 mm
- Ⓑ 22 × Excenterdübel
- Ⓒ 22 × Exzenter
- Ⓓ 22 × Rückwandhalter
- Ⓔ 4 × Schraube 3.5 × 17 mm
- Ⓙ 6 × Excenterabdeckung
- Ⓛ 4 × Schraube Ø3,5 × 15 mm für Rückwand
- Ⓝ 2 × Kleiderstangen Halterung
- Ⓞ 12 × Bodenträger
- Ⓧ 2 × Verbindungsschraube
- Ⓨ 2 × Hülsenmutter
- Ⓩ 1 × Wandbefestigungs Kit

### Türen:

- ⑦ 2 × Tür links/rechts
- ⑧ 4 × Hakenleiste
- ⑨ 2 × Spiegel
- ⑩ 2 × Griff
- Ⓛ 4 × Holzschraube 4 × 40mm für Griff
- Ⓚ 8 × Scharnier
- Ⓛ 32 × Schraube Ø3,5 × 15mm für Scharniere
- Ⓜ 12 × Schraube Ø4 × 30mm für Kleiderhaken

## Checking scope of delivery

1. Take the individual components out of the packaging.
2. Check whether the delivery is complete.
3. Check whether the product, the individual components or accessories are damaged. If this is the case, do not use the product. Contact us directly via our service portal.

Please note the information in the assembly instructions!



### wardrobe frame:

- ① 1 × plinth
- ② 2 × top/bottom panel
- ③ 4 × back panel reinforcement
- ④ 1 × left side panel
- ⑤ 1 × right side panel
- ⑥ 4 × back panel
- ⑪ 1 × clothes rail
- ⑫ 2 × shelf panel
- A 18 × wooden dowel Ø8x35 mm
- B 22 × cam dowel
- C 22 × cam lock
- D 22 × back panel bracket
- E 4 × screw 3.5 × 17 mm
- J 6 × cam cover
- L 4 × screw Ø3,5 × 15 mm for back panel
- N 2 × clothes rail bracket
- O 12 × shelf support
- X 2 × connector bolt
- Y 2 × cross dowel
- Z 1 × wall-mounting kit

### door:

- ⑦ 2 × door left/right
- ⑧ 4 × clothes hook
- ⑨ 2 × mirror
- ⑩ 2 × handle
- I 4 × wood screw 4 × 40 mm for handle
- K 8 × hinge
- L 32 × screw Ø3,5 × 15 mm for hinges
- M 12 × screw Ø4 × 30 mm for coat hooks

## Vérification du contenu de la livraison

1. Sortez les différentes pièces de l'emballage.
2. Vérifiez si la livraison est complète.
3. Vérifiez si le produit, les pièces détachées ou les accessoires présentent des dommages. Si tel est le cas, n'utilisez pas le produit. Contactez-nous directement via notre portail de services.

Veillez tenir compte des indications dans les instructions de montage !



### corps de l'armoire:

- ① 1 × plinthe
  - ② 2 × panneau supérieur/inférieur
  - ③ 4 × renfort du panneau arrière
  - ④ 1 × panneau latéral gauche
  - ⑤ 1 × panneau latéral droit
  - ⑥ 4 × panneau arrière
  - ⑪ 1 × tringle à vêtements
  - ⑫ 2 × tablette
  - A 18 × tourillon en bois Ø8x35 mm
  - B 22 × tige à excentrique
  - C 22 × verrou à excentrique
  - D 22 × support de panneau arrière
  - E 4 × vis 3,5 × 17 mm
  - J 6 × cache d'excentrique
  - L 4 × vis Ø3,5 × 15 mm pour panneau arrière
  - N 2 × support de tringle à vêtements
  - O 12 × support de tablette
  - X 2 × vis de liaison
  - Y 2 × écrou à douille
  - Z 1 × kit de fixation murale
- portes:
- ⑦ 2 × porte gauche/droite
  - ⑧ 4 × crochet porte-vêtements
  - ⑨ 2 × miroir
  - ⑩ 2 × poignée
  - I 4 × vis à bois 4 × 40mm pour poignée
  - K 8 × charnière
  - L 32 × vis Ø3,5 × 15mm pour charnières
  - M 12 × vis Ø4 × 30mm crochets porte-vêtements

## Controllo della fornitura

1. Estrarre le singole parti dall'imballaggio.
2. Controllare che la fornitura sia completa.
3. Controllare se il prodotto, le singole parti o gli accessori sono danneggiati. In tale eventualità, non utilizzare il prodotto. Contattaci direttamente tramite il nostro portale di servizi.

Si prega di osservare nelle indicazioni istruzioni di montaggio!



### corpo dell'armadio:

- ① 1 × zoccolo
- ② 2 × pannello superiore/inferiore
- ③ 4 × rinforzo del pannello posteriore
- ④ 1 × fianco sinistro
- ⑤ 1 × fianco destro
- ⑥ 4 × pannello posteriore
- ⑪ 1 × tubo appendiabiti
- ⑫ 2 × ripiano
- A 18 × spinotto in legno Ø8x35 mm
- B 22 × perno eccentrico
- C 22 × giunto eccentrico
- D 22 × supporto per pannello posteriore
- E 4 × vite 3.5 × 17 mm
- J 6 × copertura eccentrico
- L 4 × vis Ø3,5 × 15 mm pour panneau arrière
- N 2 × supporto per tubo appendiabiti
- O 12 × supporto per ripiano
- X 2 × vite di giunzione
- Y 2 × dado a barilotto
- Z 1 × kit di fissaggio a parete

### ante:

- ⑦ 2 × anta sinistra/destra
- ⑧ 4 × gancio appendiabiti
- ⑨ 2 × specchio
- ⑩ 2 × maniglia
- I 4 × vite per legno 4 × 40mm per maniglia
- K 8 × cerniera
- L 32 × vite Ø3,5 × 15mm per cerniere
- M 12 × vite Ø4 × 30mm per ganci appendiabiti

Kleiderschrank montieren  
Assembling the wardrobe

Assemblage de l'armoire  
Montaggio dell'armadio

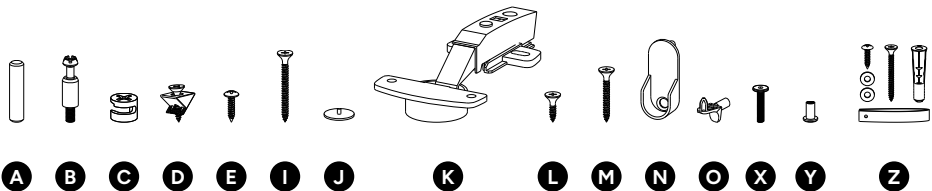
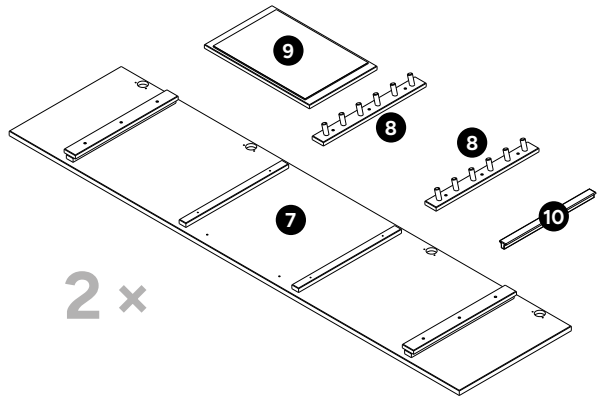
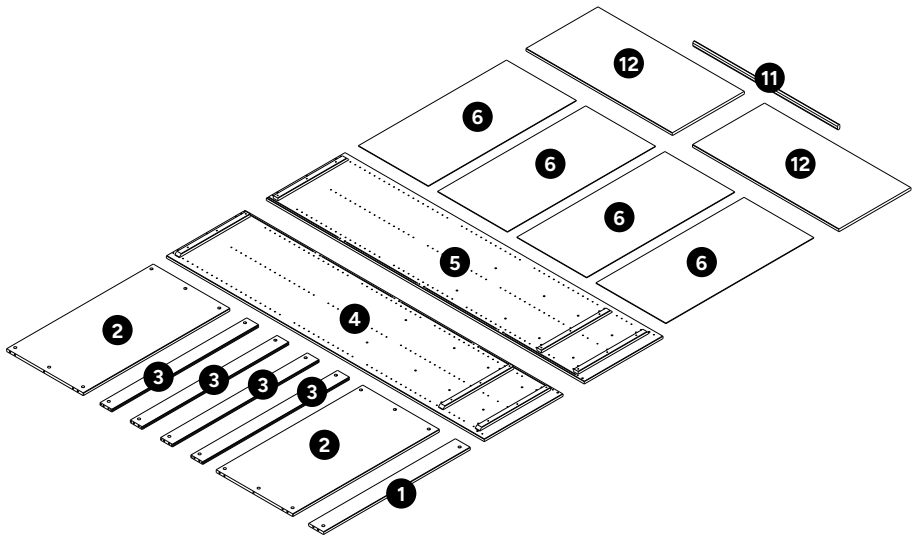

01

1 × 1    4 × 3  
2 × 2    18 × A

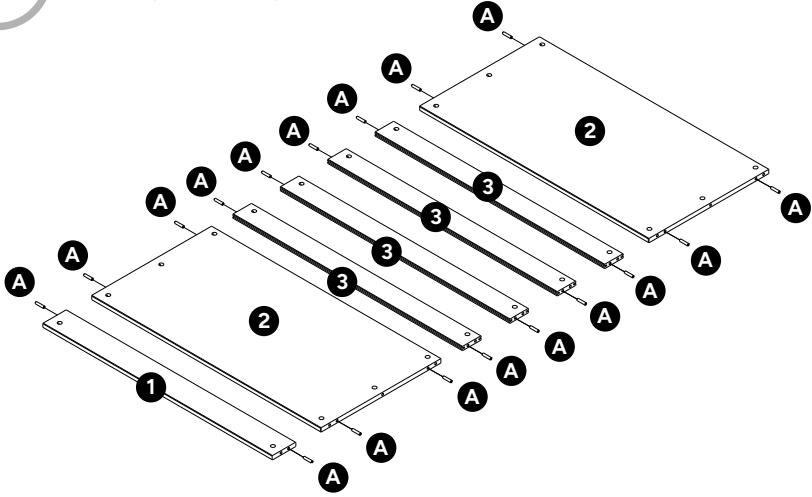

02

1 × 4    22 × B  
1 × 5

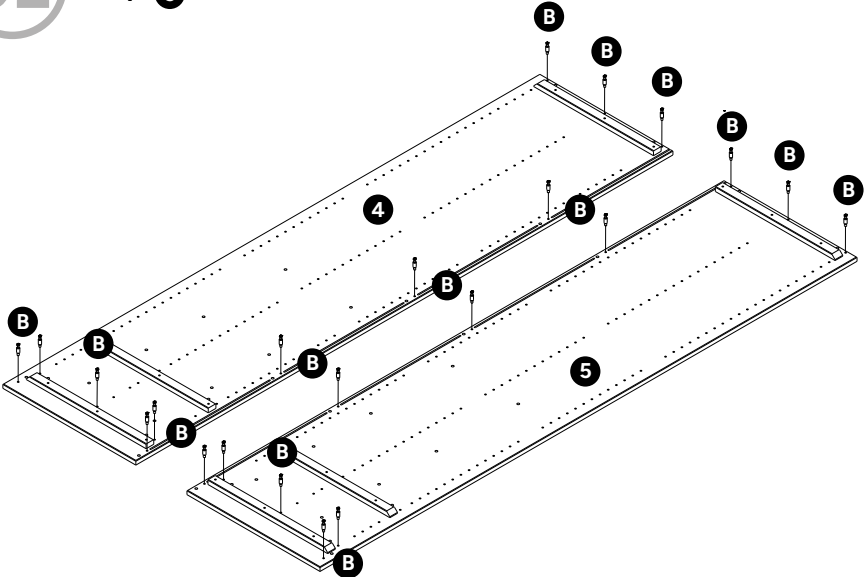

03

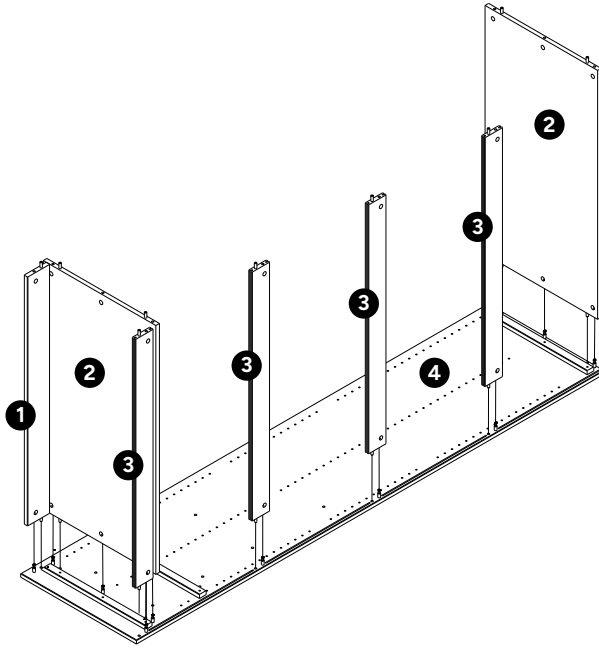

04

11 x C

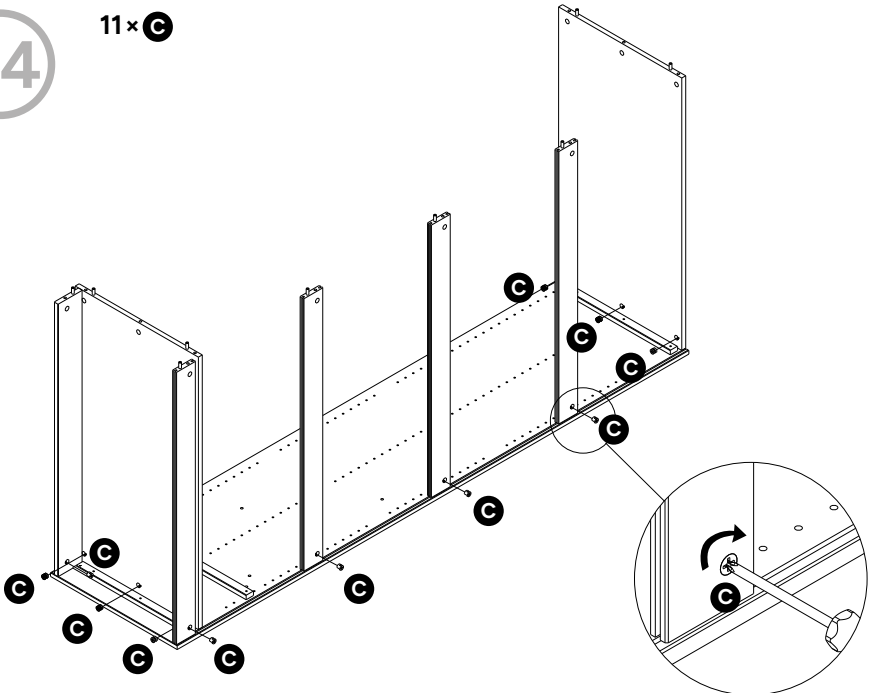

05

4 x 6

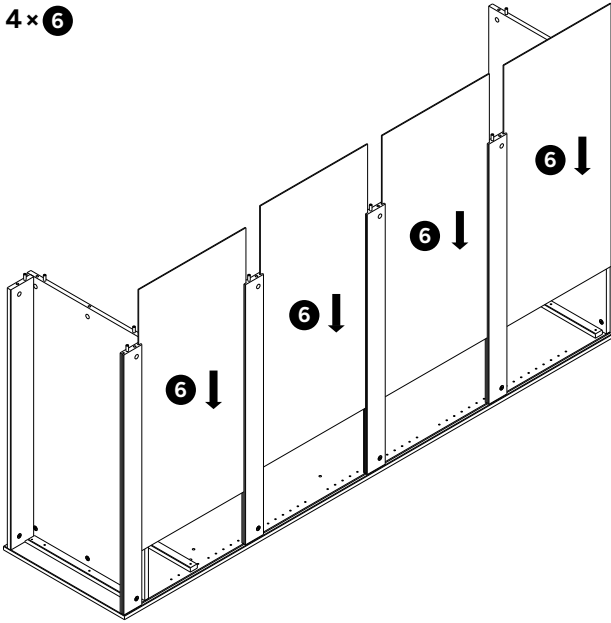

06

11 x C

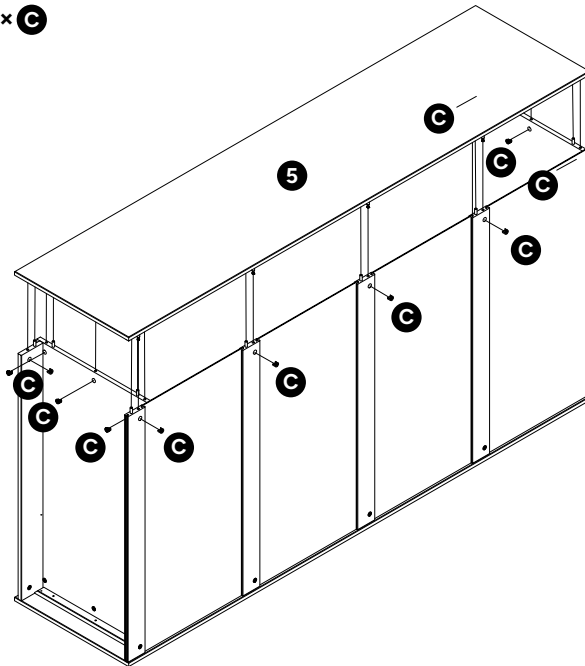

07

22 × D

4 × L

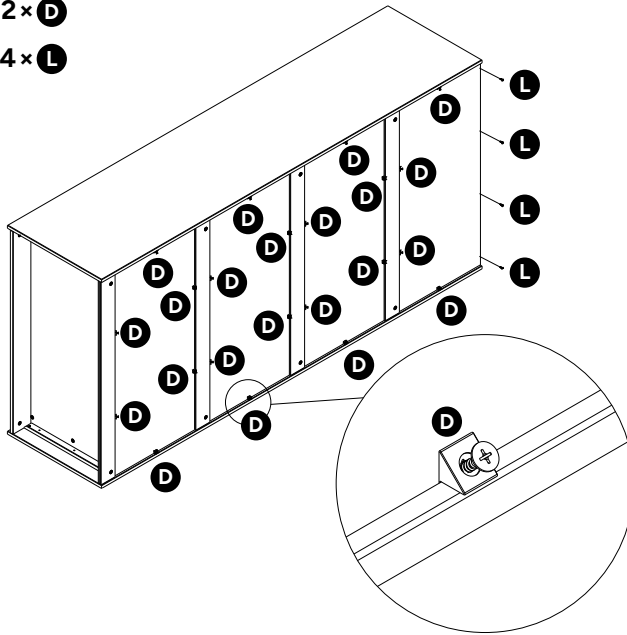

08

**Hinweis:**

Schrank Korpus vorsichtig zu zweit aufstellen.

**Note:**

Carefully lift and position the wardrobe frame with two persons.

**Remarque :**

Manipuler le corps de l'armoire avec précaution à deux personnes.

**Nota:**

Maneggiare con cautela il corpo dell'armadio in due persone.

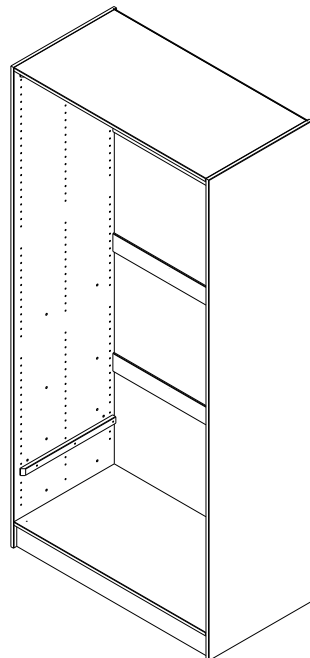

Montageschritte zur Verbindung von mehreren Korpusen.

Assembly steps for connecting multiple cabinets.

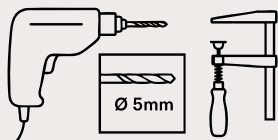

Étapes d'assemblage pour relier plusieurs caissons.

Fasi di montaggio per collegare più corpi mobile.

1

4 x X

4 x Y

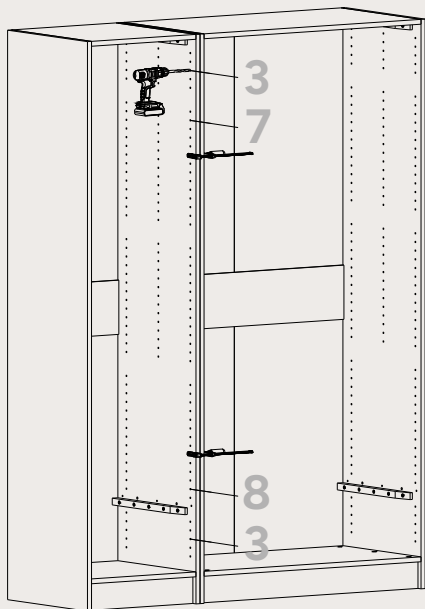

2

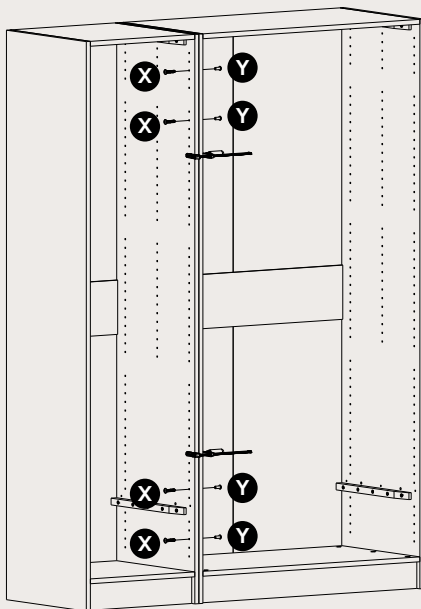

09

1 × 7

8 × L

4 × K

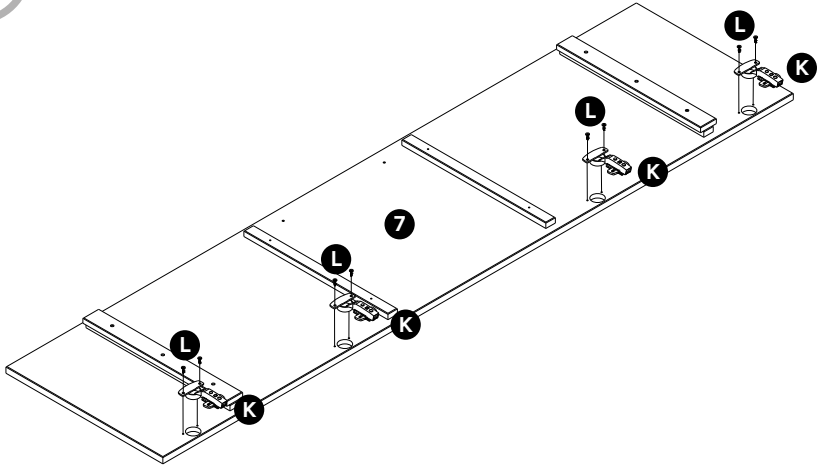

10

8 × L

**Hinweis:** Tür zu zweit montieren.

**Note:**  
Install the door with two people.

**Remarque:**  
Monter la porte à deux personnes.

**Nota:**  
Montare la porta in due persone.

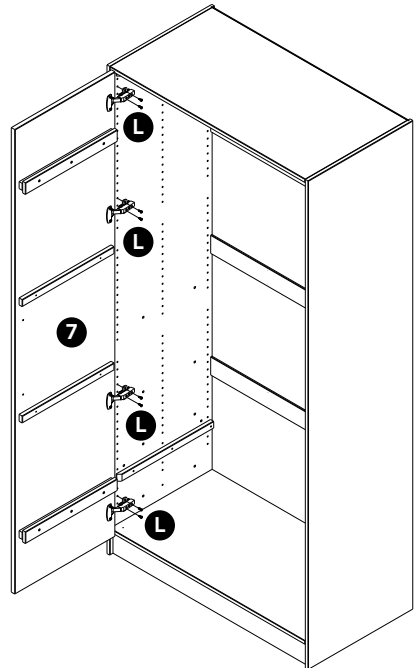

11

2 × 8

6 × M

**Hinweis:**

Die Leiste mit den Kleiderhaken nur leicht anziehen.

**Note:**

Slightly tighten the clothes hook rail.

**Remarque :**

Serrer légèrement la barre à crochets.

**Nota:**

Stringere leggermente la barra appendiabiti.

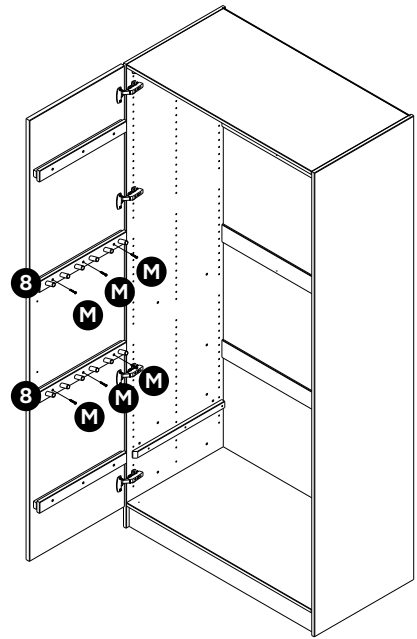

12

1 × 9

2 × D

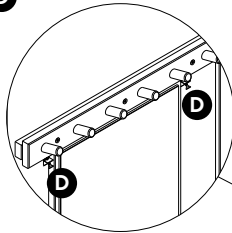

**Hinweis:** Spiegel einschieben und an der gewünschten Position fixieren.

**Note:** Insert the mirror and secure it in the desired position.

**Remarque:** Insérer le miroir et le fixer dans la position souhaitée.

**Nota:** Inserire lo specchio e fissarlo nella posizione desiderata.

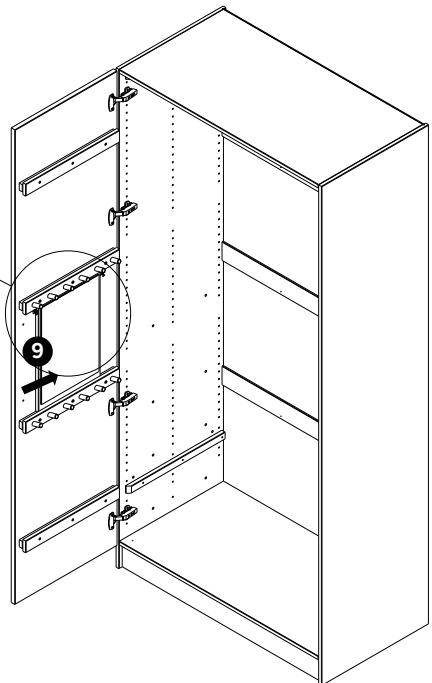

13

**Hinweis:**

Schrauben an der Hakenleiste anziehen.

**Note:**

Tighten hook rail screws.

**Remarque :**

Serrer les vis de la barre à crochets.

**Nota:**

Stringere le viti della barra appendiabiti.

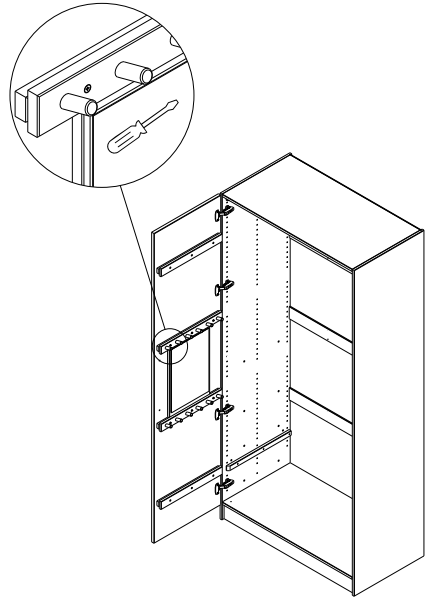

14

1 × 10

2 × 1

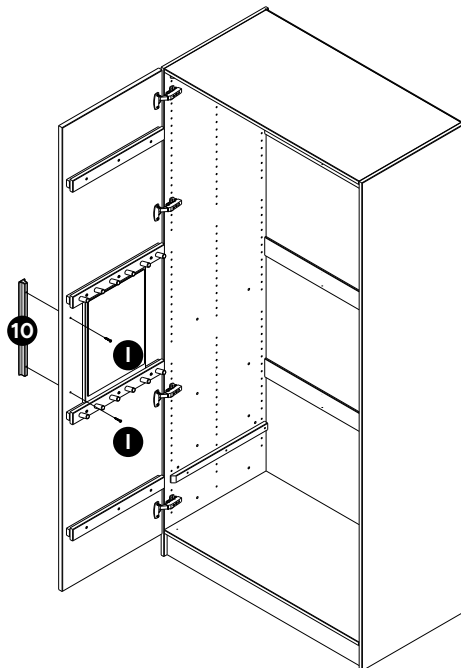

15

8 × L

**Hinweis:** Tür zu zweit montieren.

**Note:**  
Install the door with two people.

**Remarque:**  
Monter la porte à deux personnes.

**Nota:**  
Montare la porta in due persone.

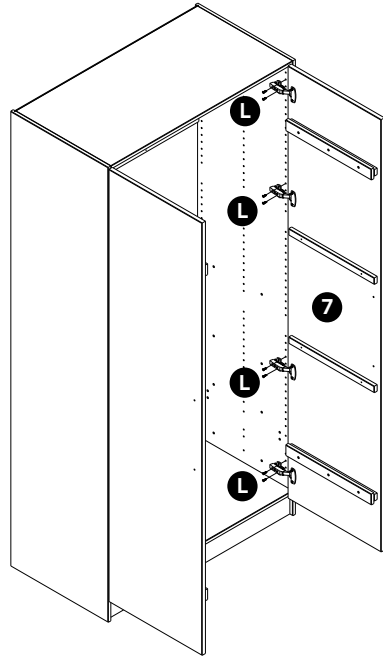

16

2 × 8

6 × M

**Hinweis:**  
Die Leiste mit den Kleiderhaken nur leicht anziehen.

**Note:**  
Slightly tighten the clothes hook rail.

**Remarque :**  
Serrer légèrement la barre à crochets.

**Nota:**  
Stringere leggermente la barra appendiabiti.

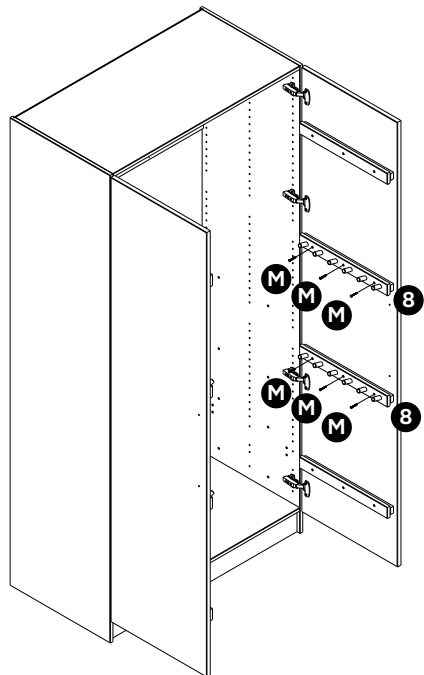

17

1 × 9

2 × D

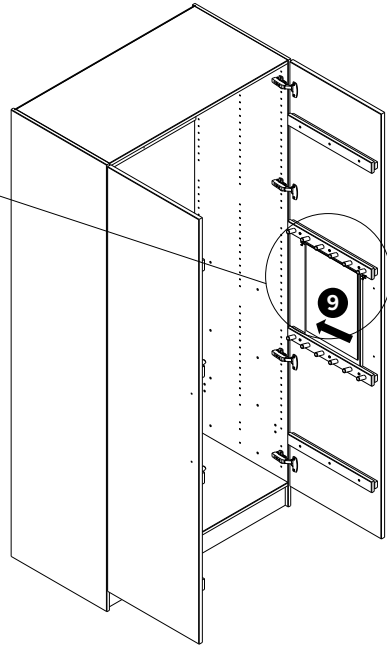
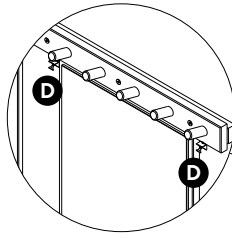

**Hinweis:** Spiegel einschieben und an der gewünschten Position fixieren.

**Note:** Insert the mirror and secure it in the desired position.

**Remarque:** Insérer le miroir et le fixer dans la position souhaitée.

**Nota:** Inserire lo specchio e fissarlo nella posizione desiderata.

18

**Hinweis:**  
Schrauben an der Hakenleiste anziehen.

**Note:**  
Tighten hook rail screws.

**Remarque :**  
Serrer les vis de la barre à crochets.

**Nota:**  
Stringere le viti della barra appendiabiti.

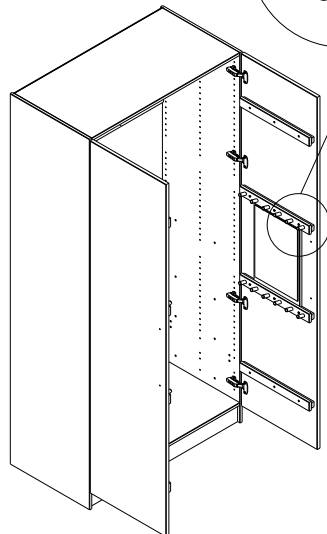
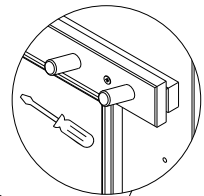

19

1 × 10

2 × 1

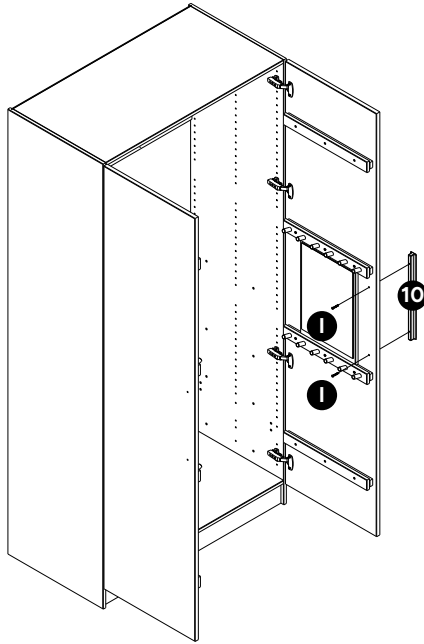

20

2 × N

**Hinweis:**

Kleiderstangenhalter an der gewünschten Position befestigen und fixieren.

**Note:**

Fix clothes rail supports in the desired position.

**Remarque :**

Fixer les supports de tringle à vêtements à la position souhaitée.

**Nota:**

Fissare i supporti per il tubo appendiabiti nella posizione desiderata.

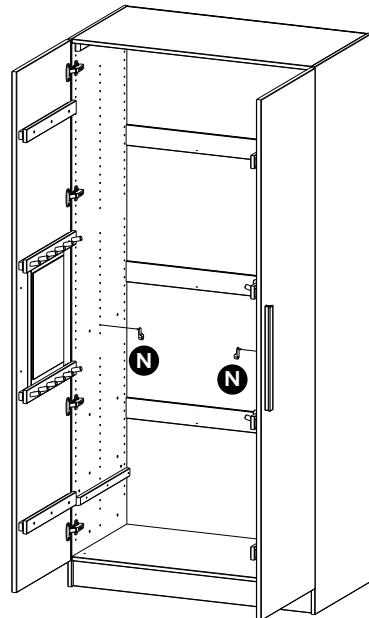

21

1 × 11

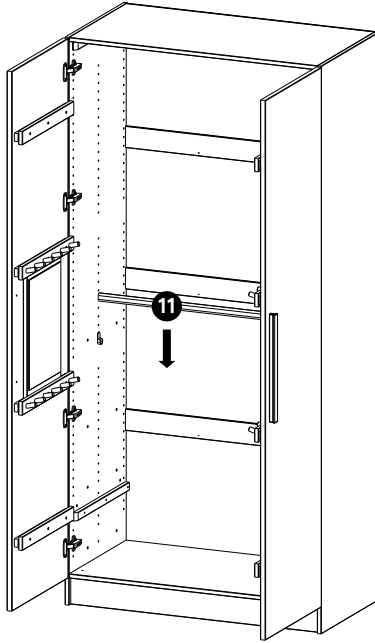

22

12 × 10

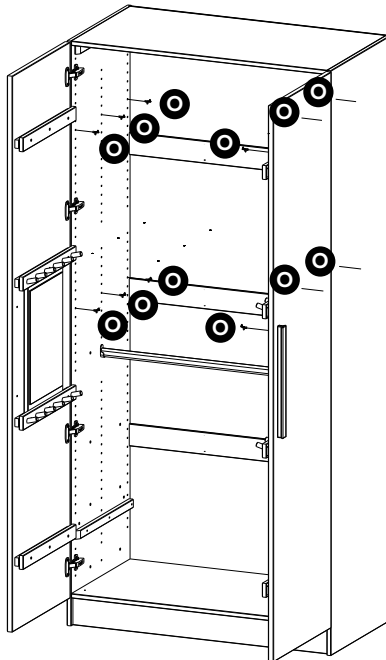

23

2 x 12

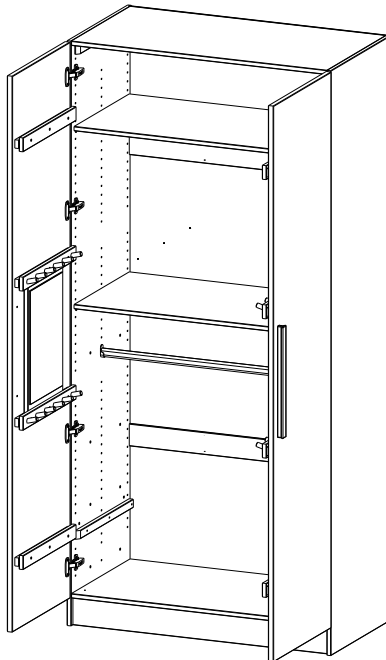
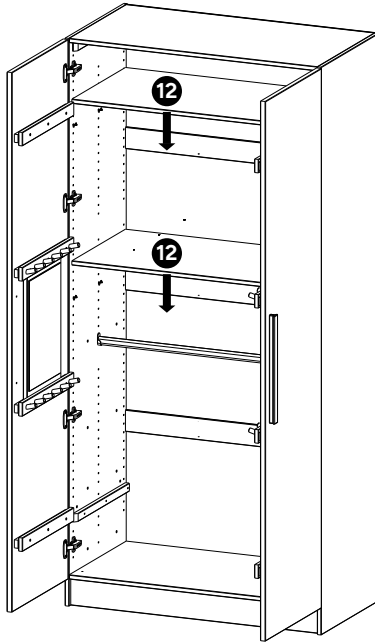

# Ehrenkind

## **Du brauchst Unterstützung?**

Scanne einfach den Code  
mit deinem Smartphone.

---

### **Need support?**

Simply scan the code  
with your smartphone.



**Ehrenkind GmbH**  
In der Knackenu 3  
82031 Grünwald  
[www.ehrenkind.de](http://www.ehrenkind.de)