

# Rückbauset Kiefer

Deconstruction set | Kit de démontage | Set di smontaggio

## Montageanleitung

assembly instructions | instructions de montage |  
istruzioni di montaggio

Ehrenkind



## Lieferumfang prüfen

1. Nimm die Einzelteile aus der Verpackung.
2. Prüfe, ob die Lieferung vollständig ist.
3. Prüfe, ob das Produkt, die Einzelteile oder das Zubehör Schäden aufweisen. Ist dies der Fall, benutze das Produkt nicht. Wende dich direkt an uns über das Serviceportal.

- 5 a/b Bein Fußteil links
- 6 a/b Bein Fußteil rechts
- 7 a/b Bein Kopfteil links
- 8 a/b Bein Kopfteil rechts
- 11 Seitenteil
- A Schraube m10×70
- B Halbmondscheibe Ø35 m10
- C Holzdübel 12×50
- U Filz 70×25
- X Inbusschlüssel 8 mm



Bitte beachte die Hinweise  
in der Montageanleitung!

## Checking scope of delivery

1. Take the individual components out of the packaging.
2. Check whether the delivery is complete.
3. Check whether the product, the individual components or accessories are damaged. If this is the case, do not use the product. Contact us directly via our service portal.

- 5 a/b leg foodboard left
- 6 a/b leg foodboard right
- 7 a/b leg headboard left
- 8 a/b leg headboard right
- 11 side frame
- A bolt m10×70
- B half moon washer Ø35 m10
- C wooden dowel 12×50
- U felt 70×25
- X allen key 8 mm

Please note the information  
in the assembly instructions!

## Vérification du contenu de la livraison

1. Sortez les différentes pièces de l'emballage.
2. Vérifiez si la livraison est complète.
3. Vérifiez si le produit, les pièces détachées ou les accessoires présentent des dommages. Si tel est le cas, n'utilisez pas le produit. Contactez-nous directement via notre portail de services.

- 5 a/b jambe pied de lit gauche
- 6 a/b jambe pied de lit droite
- 7 a/b jambe tête de lit gauche
- 8 a/b jambe tête de lit droite
- 11 partie latérale
- A vis m10×70
- B rondelle demi-lune Ø35 m10
- C cheville en bois 12×50
- U feutre 70×25
- X clé Allen 8 mm



Veuillez tenir compte des indications dans les instructions de montage !

## Controllo della fornitura

1. Estrarre le singole parti dall'imballaggio.
2. Controllare che la fornitura sia completa.
3. Controllare se il prodotto, le singole parti o gli accessori sono danneggiati. In tale eventualità, non utilizzare il prodotto. Contattaci direttamente tramite il nostro portale di servizi.

- 5 a/b gamba pediera sinistra
- 6 a/b gamba pediera destra
- 7 a/b gamba pannello testata sinistra
- 8 a/b gamba pannello testata destra
- 11 parte laterale
- A viti m10×70
- B rondella a mezzaluna Ø35 m10
- C tasselli di legno 12×50
- U sentito 70×25
- X chiave a brugola 8 mm

Si prega di osservare nelle indicazioni istruzioni di montaggio!

Rückbauset montieren  
Assembling the deconstruction set

Assemblage du kit de démontage  
Montaggio del set di smontaggio

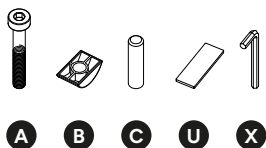
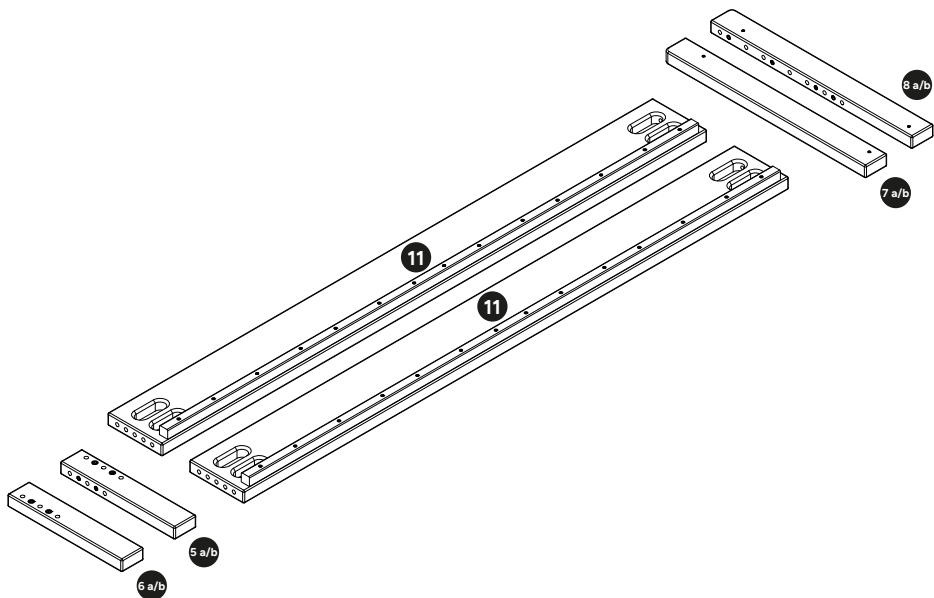

01

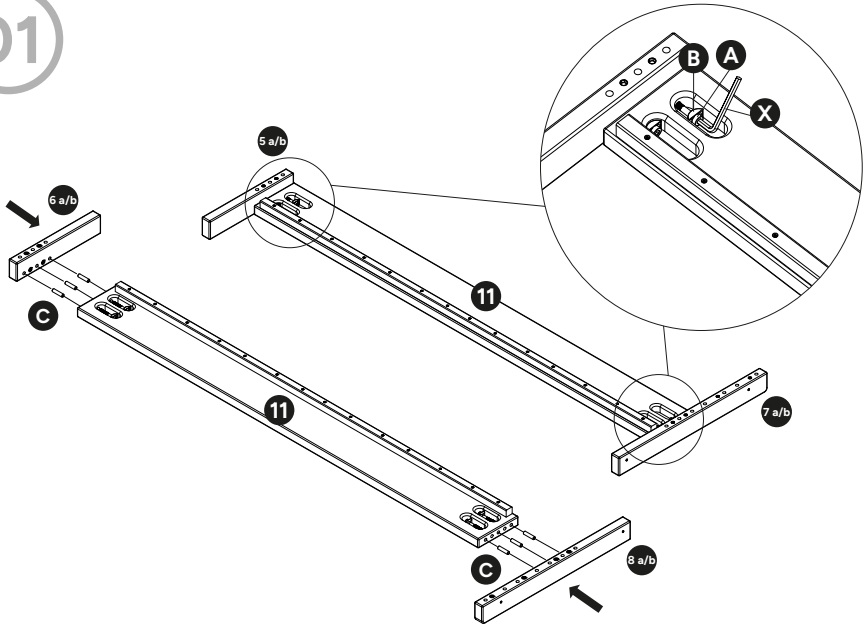

02

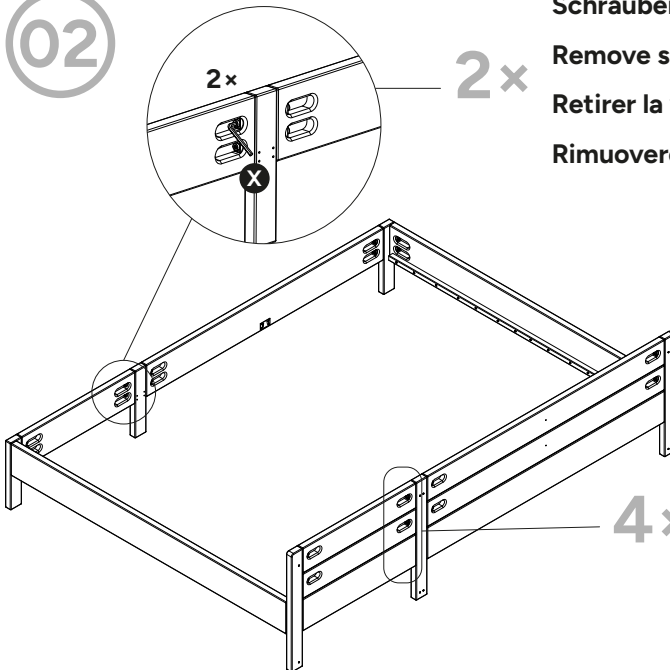

Schrauben lösen

Remove screw

Retirer la vis

Rimuovere la vit

Schrauben lösen

Remove screw

Retirer la vis

Rimuovere la vit

03

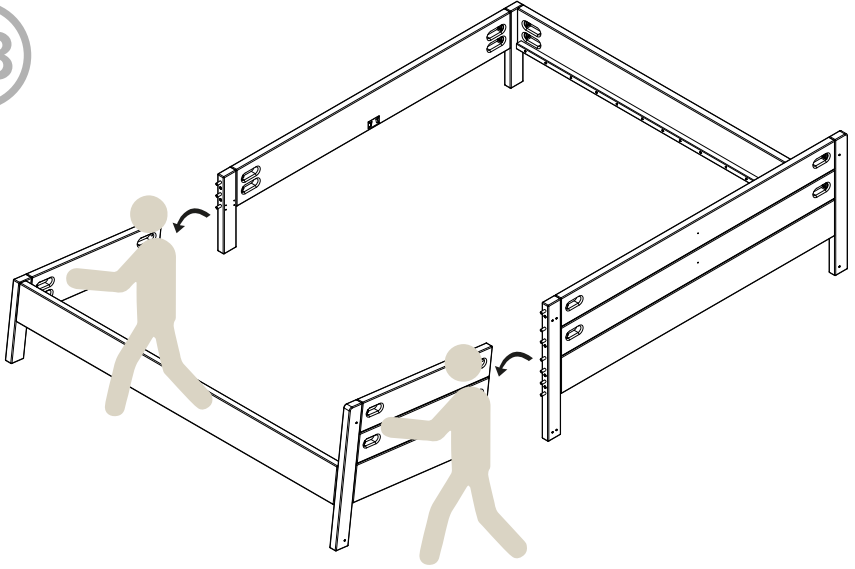

04

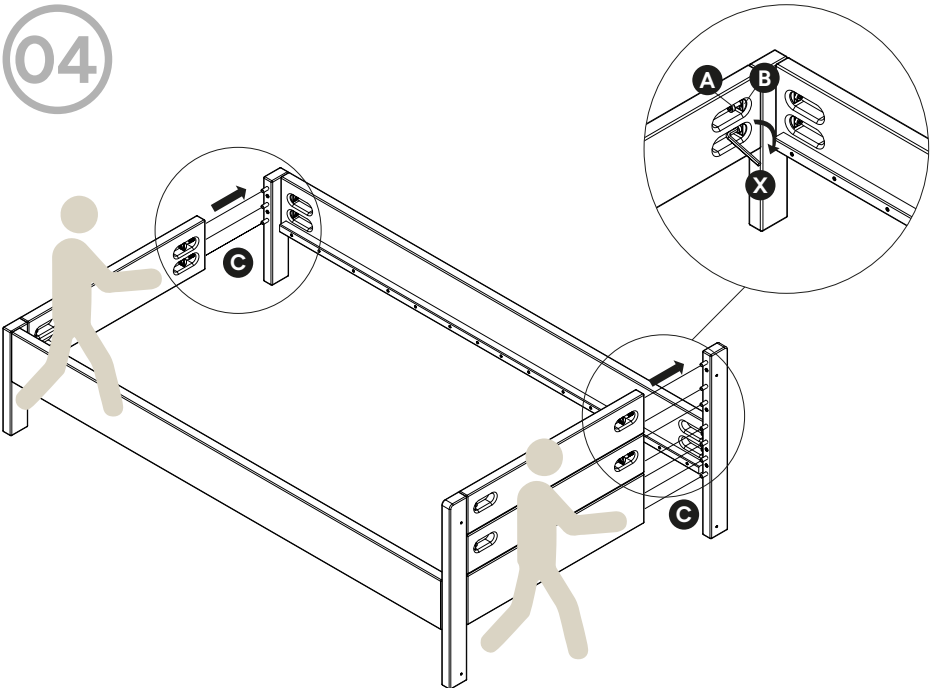

05



2x

Schrauben lösen

Remove screw

Retirer la vis

Rimuovere la vit

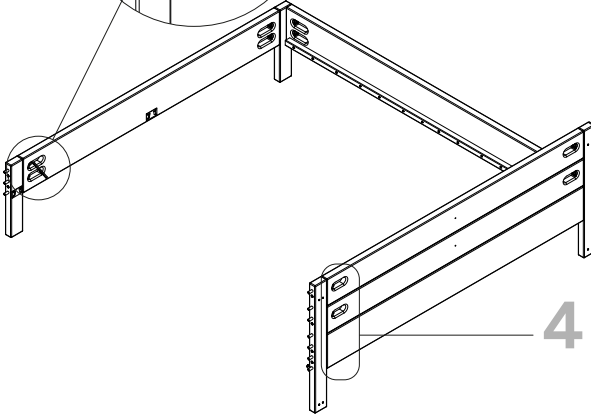

4x

Schrauben lösen

Remove screw

Retirer la vis

Rimuovere la vit

06

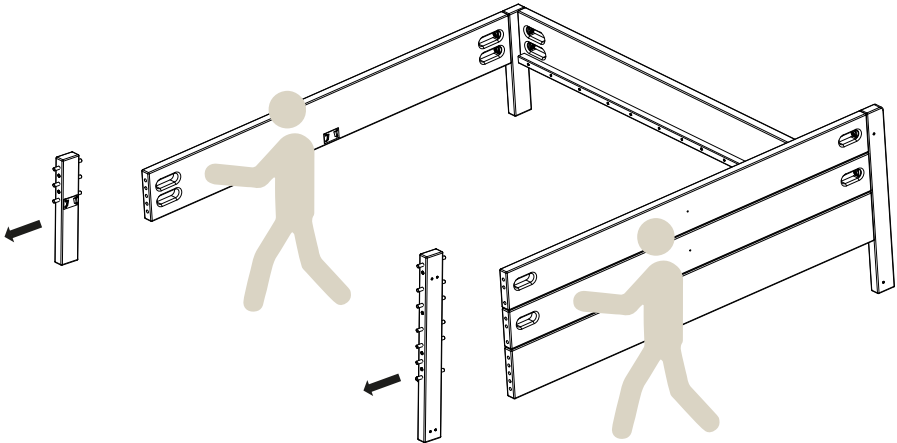



07

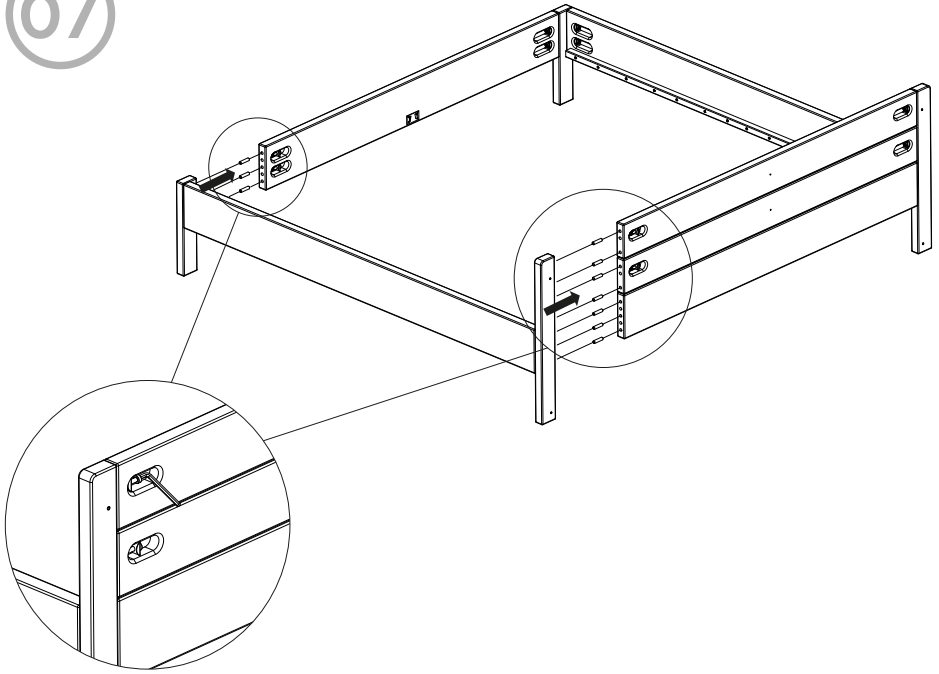

# Ehrenkind

## **Du brauchst Unterstützung?**

Besuche unser Serviceportal, scanne einfach den Code mit deinem Smartphone.

---

## **Need support?**

Visit our service portal, simply scan the code with your smartphone.



## **Ehrenkind**

formbench GmbH  
Ginsterweg 3  
74523 Schwäbisch Hall