

# Rausfallschutz Kiefer

Fall guard | Protection antichute | Protezione anticaduta

## Montageanleitung

assembly instructions | instructions de montage |  
istruzioni di montaggio

*Ehrenkind*



## Lieferumfang prüfen

1. Nimm die Einzelteile aus der Verpackung.
2. Prüfe, ob die Lieferung vollständig ist.
3. Prüfe, ob das Produkt, die Einzelteile oder das Zubehör Schäden aufweisen. Ist dies der Fall, benutze das Produkt nicht. Wende dich direkt an uns über das Serviceportal.

- 18 Brett
- 19 Fuss a
- 20 Fuss b
- N Holzdübel 10×40
- O Holzschraube 6,3×80
- P Holzschraube 4×30
- V Filz 100×25
- Y Inbusschlüssel 4 mm



Bitte beachte die Hinweise  
in der Montageanleitung!

## Checking scope of delivery

1. Take the individual components out of the packaging.
2. Check whether the delivery is complete.
3. Check whether the product, the individual components or accessories are damaged. If this is the case, do not use the product. Contact us directly via our service portal.

- 18 board
- 19 foot a
- 20 foot b
- N wooden dowel 10×40
- O wood screw 6.3×80
- P wood screw 4×30
- V felt 70×25
- Y allen key 4 mm

Please note the information  
in the assembly instructions!

## Vérification du contenu de la livraison

1. Sortez les différentes pièces de l'emballage.
2. Vérifiez si la livraison est complète.
3. Vérifiez si le produit, les pièces détachées ou les accessoires présentent des dommages. Si tel est le cas, n'utilisez pas le produit. Contactez-nous directement via notre portail de services.

- 18 planche
- 19 pied a
- 20 pied b
- N cheville en bois 10×40
- O vis à bois 6,3×80
- P vis à bois 4×30
- V feutre 70×25
- Y clé Allen 4 mm



Veuillez tenir compte des indications dans les instructions de montage !

## Controllo della fornitura

1. Estrarre le singole parti dall'imballaggio.
2. Controllare che la fornitura sia completa.
3. Controllare se il prodotto, le singole parti o gli accessori sono danneggiati. In tale eventualità, non utilizzare il prodotto. Contattaci direttamente tramite il nostro portale di servizi.

- 18 tavola
- 19 piede a
- 20 piede b
- N tasselli di legno 10×40
- O viti per legno 6,3×80
- P viti per legno 4×30
- V sentito 70×25
- Y chiave a brugola 4 mm

Si prega di osservare nelle indicazioni istruzioni di montaggio!

Rausfallschutz montieren  
Assembling the fall guard

Assemblage du protection antichute  
Montaggio del protezione anti-caduta

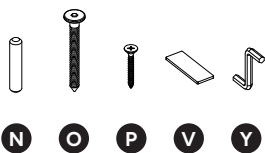
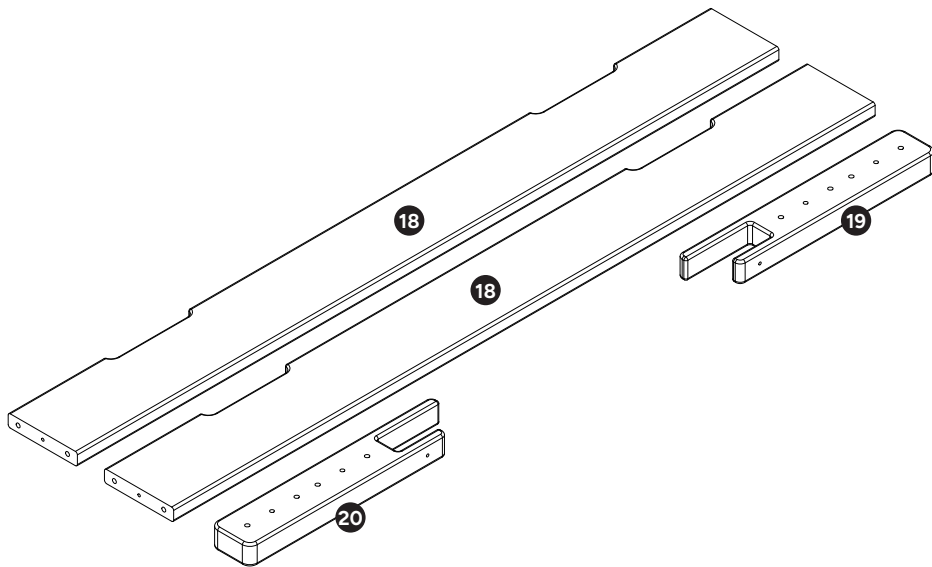

01

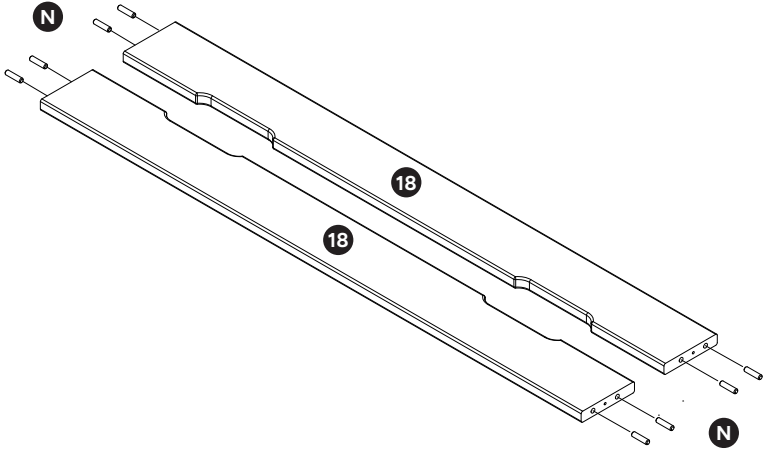

02

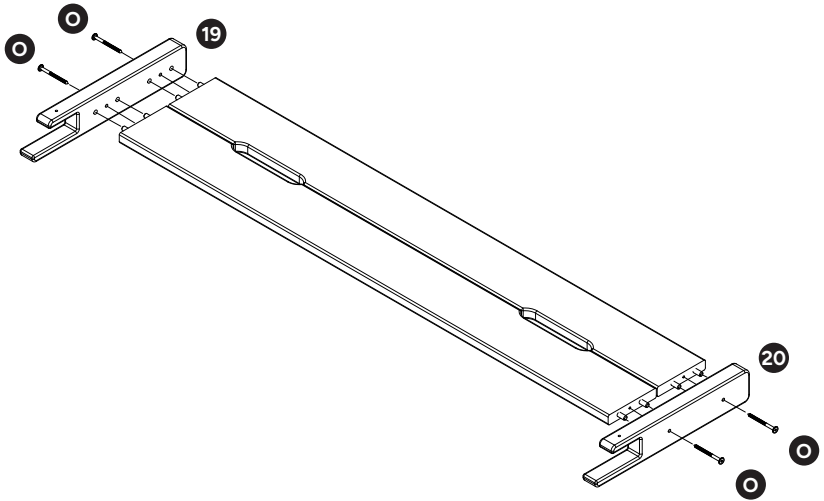

03

Filz anbringen

Attach felt

Appliquer le feutre

Applicare il sentito

2x V

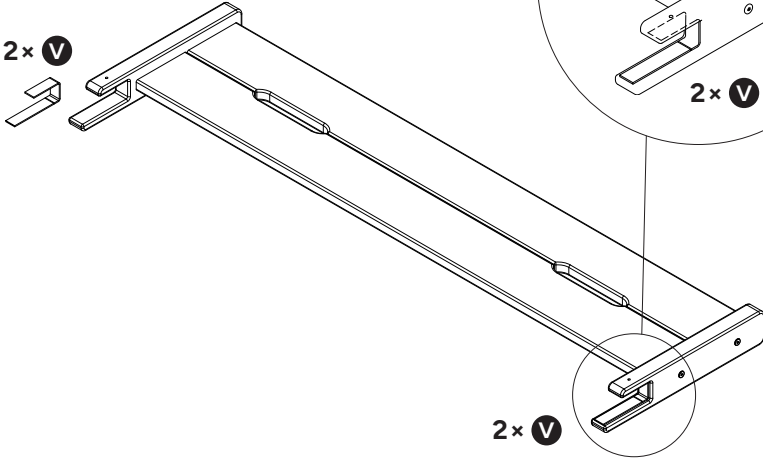

04

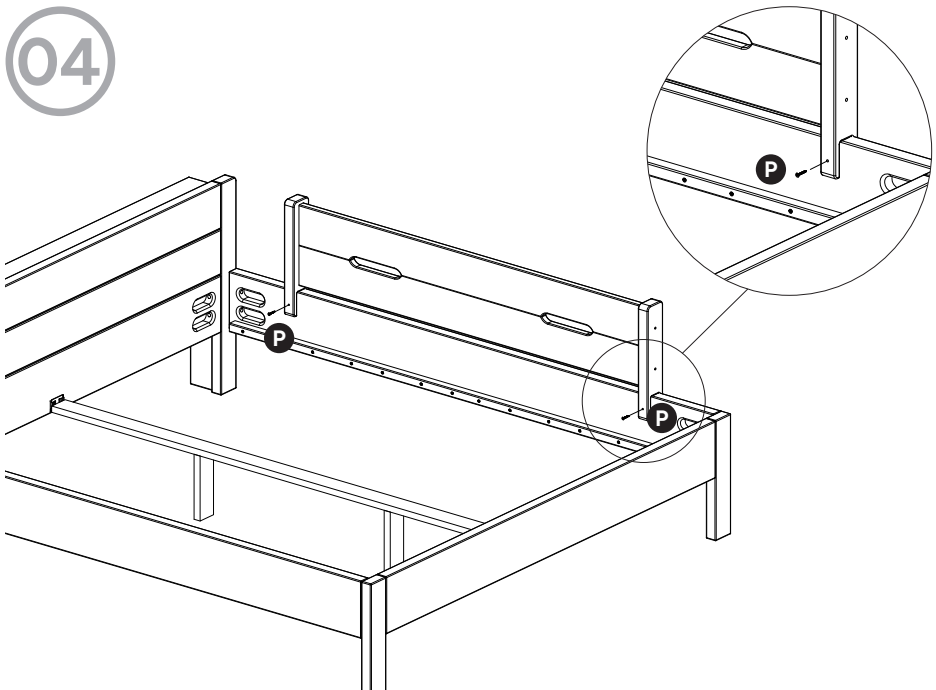

# Ehrenkind

## **Du brauchst Unterstützung?**

Besuche unser Serviceportal, scanne einfach den Code mit deinem Smartphone.

---

## **Need support?**

Visit our service portal, simply scan the code with your smartphone.



## **Ehrenkind**

formbench GmbH  
Ginsterweg 3  
74523 Schwäbisch Hall